

# Introduction to Guideline Procedures— Part 3: Navigation

By Fred Devos, Chris Le Maillot and Daniel Riordan



D. Riordan

*Proper line referencing is a critical component of safe cave diving*

*The following article is aimed at providing an introduction to guideline procedures. The information presented should in no way take the place of formal training, practice and experience.*

Guideline use for navigation is not restricted to overhead environments; many environments lend themselves to guideline use. At first, this observation may seem trivial. In reality, however, navigation with a guideline entails several elements beyond sticking to a line and blindly following it.

### LINE FOLLOWING

Guidelines should be traveled and referenced completely. Dive teams should ensure that they are always following a continuous guideline. Sharp bends, curves or a guideline buried under silt, may be hiding an intersection in the line (blind intersection), or a damaged or broken line. Neglecting to swim part of a line could have catastrophic effects on the return portion of a dive.



*Proper line following is critical when cave diving*

### DISTANCE FROM THE GUIDELINE

Divers should never be further than arm's reach from the guideline. When facing an emergency or loss of visibility, divers must be able to make physical contact with the line. This ensures them both a point of reference and orientation in a potentially dangerous situation. The misconception that merely having sight of the line is sufficient has led divers into hazardous scenarios. For instance, the clear waters of the Yucatan can lead a careless diver to venture appreciably beyond the "arm's reach" distance from a guideline. This, then, could place them at risk in the event they find themselves in a section of a cave passage that is more susceptible to percolation. Once the silt on the cave ceiling is disturbed, divers could find themselves in a no-visibility situation off the line. Percolation is common in low-flow caves.

Proper line-following is also vital to conserving the cave environment. Though, sadly, there is always a certain amount of diver impact, the goal of divers should be to minimize the damage radius to a short distance from either side of the guideline.

### POSITIONING AND TRIM



*Good buoyancy and trim is essential to cave diving*

Proper equipment configuration, coupled with horizontal trim, good buoyancy control and adequate propulsion techniques, are key elements to prevent unnecessary stress on the line. Crossing and positioning oneself under the line could possibly lead to severe entanglement in the manifold assembly, which is by far the worst part of the equipment to get snagged. A prone position ensures effective hydrodynamics and facilitates efficient referencing.

### TEAM POSITIONING

When navigating with a guideline, it is vital that teams establish and maintain a certain order throughout the dive. Furthermore, it is important that team members make every effort to position themselves strategically. When swimming through a restricted passage, for instance, there is no choice but to adopt a single-file formation. However, in a larger passage, it can be beneficial for divers to be slightly staggered, thereby expanding each team member's view of the environment and of other team members. This will provide easier communication, and allow divers to avoid the wash of the fins in front of them.

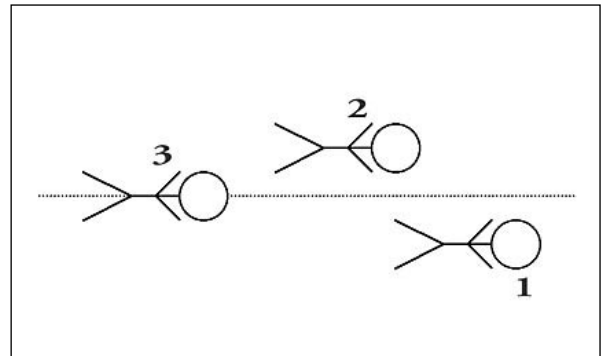

*Proper formation is essential for good communication*

An important element of navigation is the need to look ahead and pay particular attention to what is approaching. When teaching cave divers, instructors try to coach their students to look ahead of them as far as they can see. This helps them to prepare for restrictions, to anticipate changes in depth, and to prepare for entering silty areas; it also facilitates passive communication, and helps establish points of reference.

### ORIENTATION AND REFERENCING

Although a guideline is vital to certain dive plans, one must also be aware of the environment. For a long time, cave divers have known the value of carefully and thoughtfully referencing the environment. This is because certain environments can look very different on the way in than they do on the way out, and there's nothing worse than exiting on a line and not recognizing one's surroundings. This can lead divers to confusion, disorientation and increased levels of stress.



While swimming alongside a guideline, divers should pay attention to as many details as possible; this would include color and type of line, line markers, position of the line and tie-offs, and general features of the environment. This is conducted in correlation with depth, time and gas. A good diver is always aware of such information relative to his or her return journey.

It is also a good practice to periodically look back and familiarize yourself with how the environment will look on your return trip. This is known as “back-referencing” and is particularly important at restrictions or other navigational challenges. The exit portion of a dive may present limited visibility, and a mental image of key areas can facilitate an efficient return.



*Back referencing is a good habit to get into*

## COMPASS

Even when navigating with the help of a guideline, a compass can be very useful. Although the line indicates the route of travel, a compass will aid in determining the general heading. Good orientation and referencing should include knowing one’s direction of travel. This becomes very helpful if one was to become disoriented or lost from the line.

## PACE (SPEED)

When using a guideline to navigate out and back, it is important to properly pace the dive. The first leg of the trip should be undertaken slowly and carefully, thereby allowing for an easy pace during the return leg of the dive. Additional tasks, such as photography, surveying, or casual “site-seeing,” should be kept to the entry portion of the dive. This way, when it is time to turn around, making an efficient exit becomes the team’s principal task.

## COMMUNICATION

While following a guideline, lights provide team members with an easy and effective means of signaling.

Passive communication allows team members to constantly monitor each other’s state. By keeping their light beams in the field of vision of another team member, individuals are automatically communicating their presence and their general condition.



*Passive communication is an important component of underwater communication*

A light pointed ahead, moving purposefully, indicates a diver without a problem, whereas the absence of light or a quick movement can indicate that something is wrong. A light that is constantly pointing down can greatly hamper communication and referencing, and should be avoided.

Active communication consists of signals being directed to specific team members, and these light signals require a response.

## EMERGENCY SITUATIONS

As a result of increased stress and hyperventilation, emergencies are likely to give rise to high CO<sub>2</sub> levels. This will decrease a diver’s ability to make sound navigational decisions. As stress increases, so does perceptual narrowing. Therefore, travel on a guideline must be made with anticipation of an arduous and more challenging return journey.

The margin for error is always smaller during the return portion of a dive, largely because of gas and time constraints. Navigational indecision can waste even more time and gas. Proper guideline navigation can greatly assist during emergency situations such as a lost team member, lost line, gas sharing or visibility loss.

Self-sufficiency is important in building a strong and efficient team, and navigation is an essential part of this. One cannot rely on another team member not to make a mistake. In fact, what makes a proficient team is the ability for each team member to bring forth his or her individual competence and awareness.



*It is important that divers not cut corners*